

Fujifilm Endoscopy System

Electronic Video Endoscopy and  
Endoscopic Ultrasonography

# New horizons in Endoscopy

**FUJIFILM**

## ► Enhancing the quality of life of people worldwide

Fujifilm is known as the world's largest photographic and imaging company and is pioneering in diagnostic imaging and information systems for health-care facilities. The current endoscopic equipment provides high-definition video endoscopy and endoscopic ultrasound for gastroenterologists and pulmonologists. The actual range of endoscopes and the EPX-4450HD processor technology come with FICE Dual Mode and DICOM on-board.

We will use leading-edge, proprietary technologies to provide top-quality products and services that contribute to the advancement of culture, science, technology and industry, as well as improved health and environmental protection in society. Our overarching aim is to help enhance the quality of life of people worldwide.

Nowadays Fujifilm entities operate in over 50 group companies in Europe and employ more than 5,000 people engaged in R&D, manufacturing, sales, and service support.

### Innovative solutions

As one of the leading companies in the development of endoscope technology, Fujifilm regularly sets new benchmarks in the industry, for example with devices for double balloon endoscopy and transnasal endoscopy. However, the focus at Fujifilm is very much on holistic patient care. Our service portfolio therefore also includes competent technical assistance, a comprehensive range of hygiene products and individual consulting.

### New opportunities

Whether it is with the most advanced optical technology, state-of-the-art digital image processing or new examination methods, Fujifilm is always creating new opportunities in the world of endoscopy. In this way, we are making a significant contribution to the early detection of diseases and their successful treatment.

Dedicated research, the continuous enhancement of our technology, the highest quality demands and close working relationships with international specialists set the global standard in Fujifilm endoscopy and endosonography.

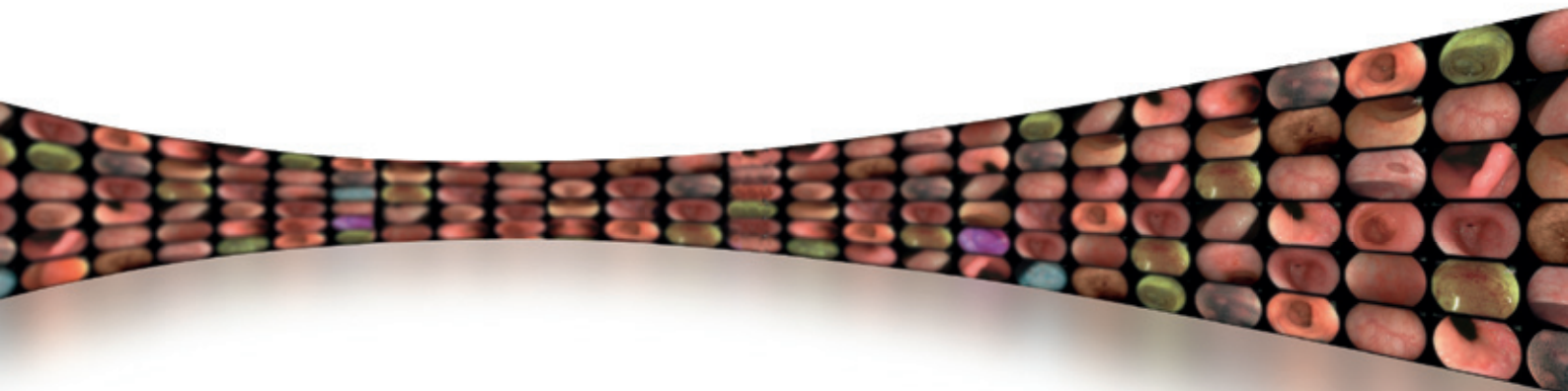

## ▶ Index

600 series CMOS Technology	4–9
FICE	10–11
ColoAssist II	12
600 series CMOS endoscopes	13
Super CCD 590 series endoscopes	14–16
ColoAssist	17
Super CCD 580 series endoscopes	18–19
Double Balloon Endoscopy	20–23
2500 system	24–25
530 series upper gastrointestinal endoscopes	26–27
530 series duodenum endoscopes	28
530 series lower gastrointestinal endoscopes	29–30
FlushKnife	31
Endoscopic ultrasonography	32–35
CO <sub>2</sub> insufflator/Water pump	36
Synapse - NX/DICOM	37
Technical specifications	38–39

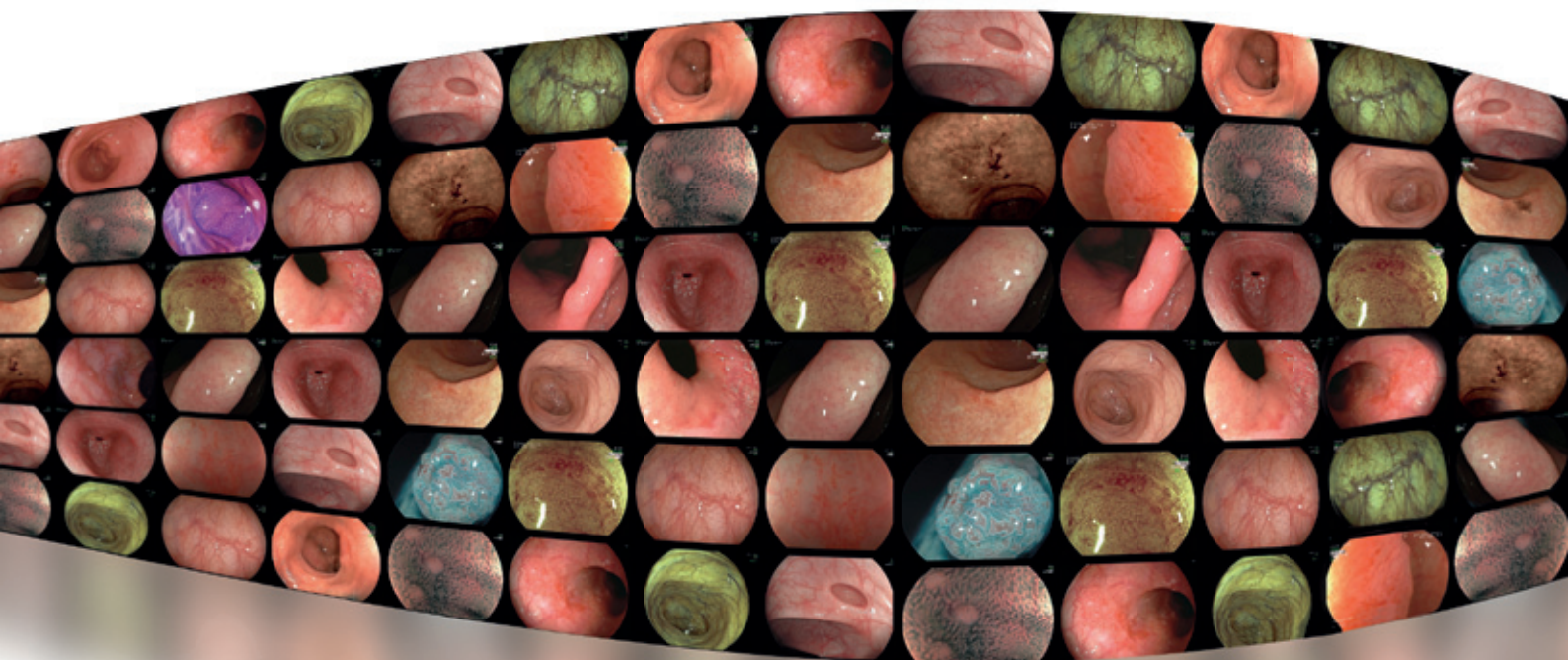

## 600 series CMOS endoscope & 4450HD system: a solution for new horizons in endoscopy realized by CMOS Technology

With advanced total solutions, Fujifilm is ready to fulfill a broad range of diagnostic and therapeutic endoscopic requirements.

600 series CMOS endoscopes feature leading-edge optical technologies to provide clear, bright endoscopic images for easier and more accurate diagnosis. The ergonomic grip design ensures a smooth and comfortable handling. The fully digital processor EPX-4450HD employs state-of-the-art digital signal processing. This system is also optimized to employ the latest FICE imaging capability. Fujifilm's endoscopy system is a total solution to support image input, processing and sharing, surely contributing to more efficient endoscopy from now on with its excellent performance.





- ▶ Fits right. Moves agilely.  
Light-weight grip for high operability

The newly developed grip fits gently into your hand, allowing full use of this high-performance endoscope. Materials, processing and choice of parts have all been reviewed to reduce the grip weight for greater maneuverability. The design is improved also to allow easier cleaning and disinfection. G-5 grip and 600 series endoscope in combination offer you added amenity in routine diagnosis.



## G-5™ ENDOSCOPY

### Designed lighter & slimmer

20% less in weight and 10 mm slimmer than that of our conventional product. The angle operation knob is remodeled to accommodate the fingers more firmly with better fit.

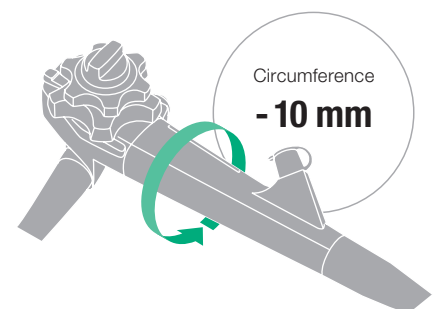

## Improved operability

New positioning of the functional switches, air/water and suction valve minimize finger travel and improve efficiency.

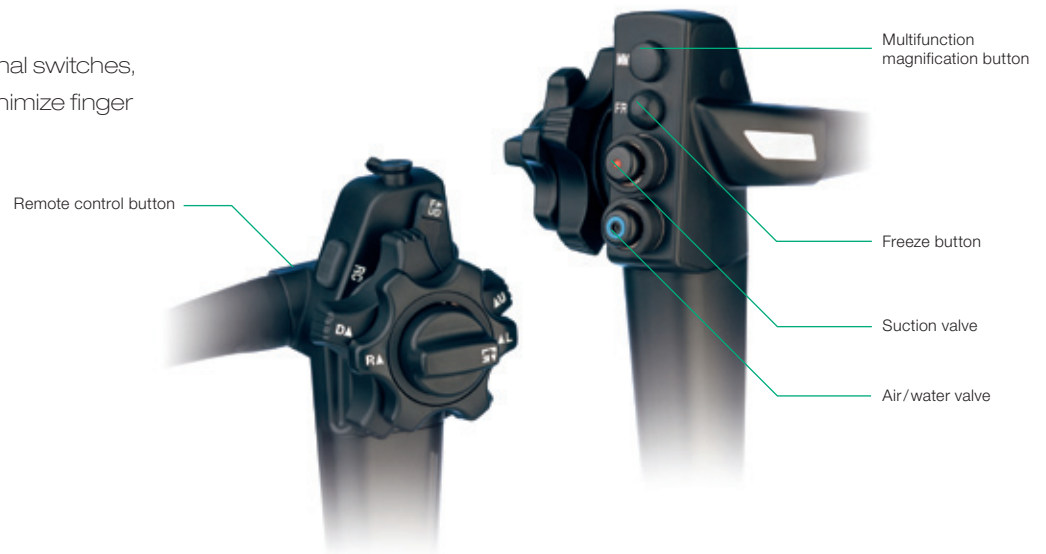

## Water jet function

Main endoscopes for the lower gastrointestinal tract have a water jet nozzle in addition to the forceps channel. The water jet nozzle effectively removes mucus on the surface being examined.

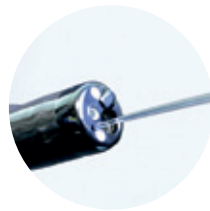

## Improved cleaning and disinfection

Cleanliness and safety focused on full defense against contamination. Easily soiled air/water valve is removable and autoclavable. A smoother, flatter surface assures all areas receive optimal contact with cleaning and high-performance disinfecting solutions.



## Light-weight connector

The connectors incorporated in the 600 and 500 series endoscopes are slim, light-weight, and easy to handle. Procedures are easy when the endoscope has to be removed/attached for cleaning and disinfection on every occasion of endoscopy.



## Flexible portion

In upper and lower gastrointestinal endoscopy, the great flexibility of the endoscope allows easy insertability and the comfort of the examinee.



The leading-edge 600 series CMOS endoscopes with full digital processor EPX-4450HD realize advanced observation and diagnosis

► CMOS Technology



Over megapixel CMOS image sensor producing super-high resolution image

By adopting over megapixel CMOS image sensor, 600 series endoscopes enable super-high resolution image to be produced. And the leading-edge CMOS Technology realizes less noise and brilliant image. To adopt CMOS image sensor can change the analog signal to digital in the tip of scope. During transmission of signal, the digital signal is much less affected by the noise from the outside. Those features make advanced observation and diagnosis possible.

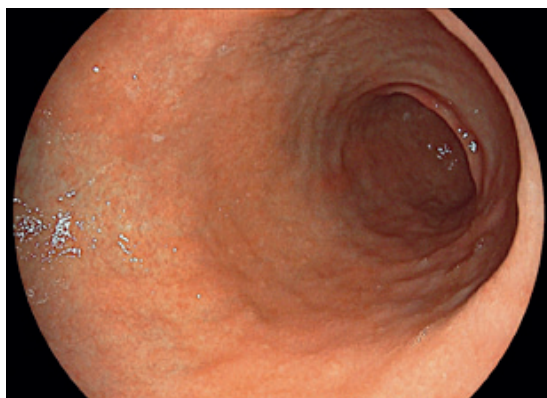

EG-600WR

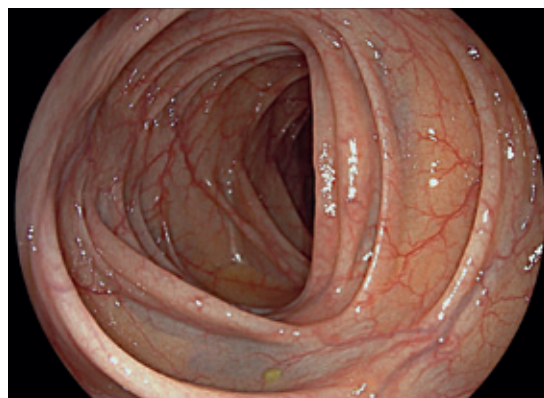

EC-600WM/WI/WL

Megapixel 60P (60 frames/s progressive) video realizes smooth and clear video ability

CMOS Technology realizes 60P video even though over megapixel. With the 60 frame progressive scanning method, it is possible to produce not only smooth and clear video but also super-high resolution and less blur still images.

Progressive



All lines are being read out at the same time

60P  
60 images / 1 sec  
Each image is over one Megapixel

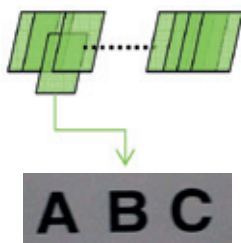

Interlaced



First scan (red line only) , second scan (blue line only)

60i  
60 images / 1 sec  
Each image only contains half of the scan



Freeze  
moving object

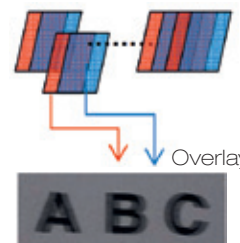



## ▶ Close Focus with CMOS Technology



### Close Focus with CMOS Technology enhance image for diagnosis

The newly designed high performance optical system enhances close focus observation capability up to 2 mm. The focus at the edges of an image has been improved, minimizing distortion in observation of a lumen. Through a combination with the Megapixel CMOS image sensor, high performance optical system assists various observations ranging from close-up to distant views.

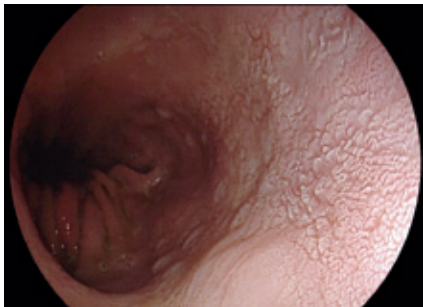

EG-600WR

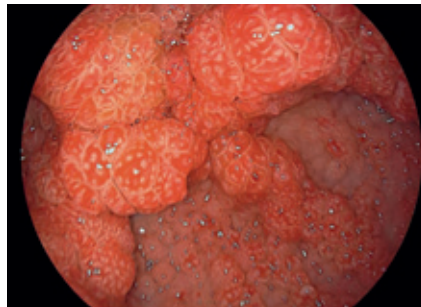

EG-600WR

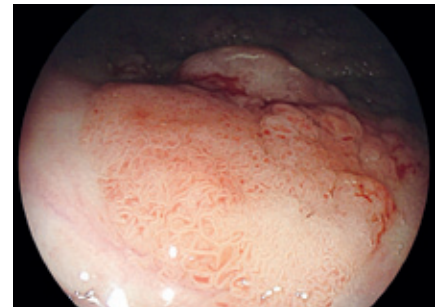

EC-600WM / WI / WL

## ▶ Anti-blur function

### Anti-blur function: extracting the best still image from multiple images

The anti-blur function offers sharpest and clearest images for review and documentation in any occasion.



\* This diagram shows how the function works

A sequence of images always kept in the background

▶ Freezing the image during the examination

▶ Automatic selection and display of the sharpest image

## ▶ Auto photometric control

### Achieving always optimal illuminated images with automatic control of the photometric mode

The automatic photometric mode optimally adjusts the lighting in accordance with the positioning of the endoscope, providing you with a well-balanced picture from close-up to distant focusing.

\* Available with the 600 and 500 series endoscopes



## ▶ Water jet function



The gastroscope and colonoscope both feature a water jet function which aids visualization for both diagnostic and therapeutic procedures.



## FICE (Flexible spectral Imaging Color Enhancement)



FICE – “Flexible spectral Imaging Color Enhancement” – in the new EPX-4450HD yields diagnostic results without any need for tissue staining. The procedure digitally limits the wavelengths of the light and displays it in up to ten different color combinations. The endoscope switch allows physicians to switch between the conventional image and the FICE image in a split second, ensuring an uninterrupted examination with the eyes always concentrated on the monitor.

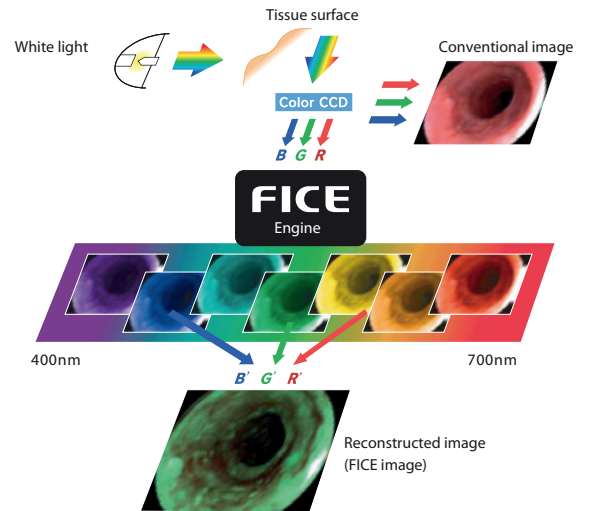

### ► FICE with CMOS Technology

#### FICE combination with CMOS Technology provides advanced FICE image

Through higher resolution and improved noise reduction, FICE images are more sharp and clear than ever. It enables easier differentiation between lesion-affected and non-affected tissue.

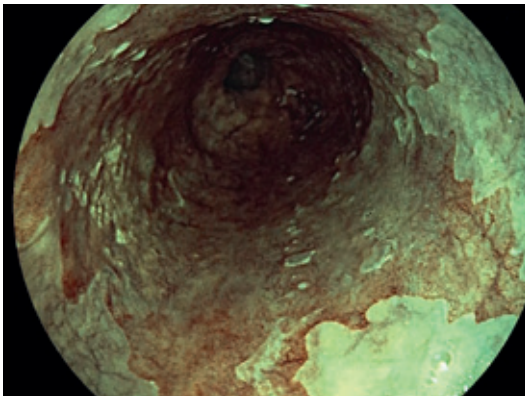

FICE1 Esophagus

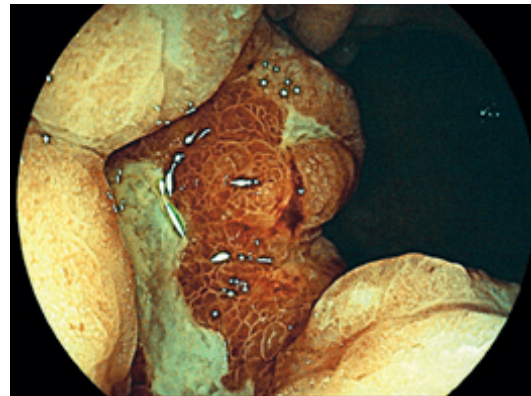

FICE1 Stomach

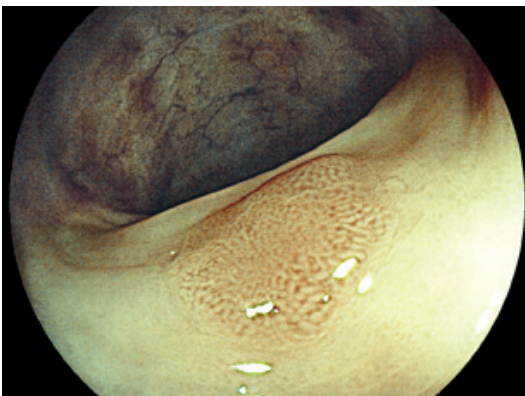

FICE1 Colon

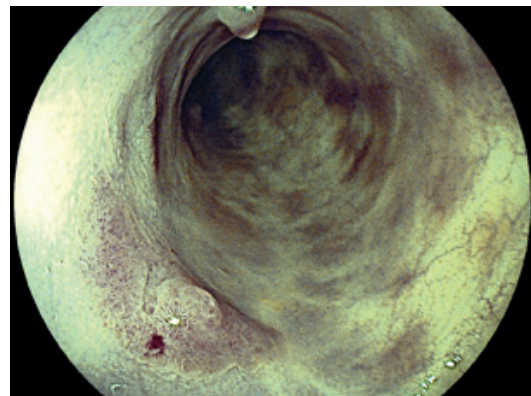

FICE8 Colon

## E-Zoom (Electronic Zoom) provides better visibility

E-Zoom image can be provided by pressing the scope button once. Normally, E-Zoom enhance noise of image. However less noise 600 series FICE image allow to use E-Zoom function. It is possible to observe the detail of surface pattern as well as vascular pattern.

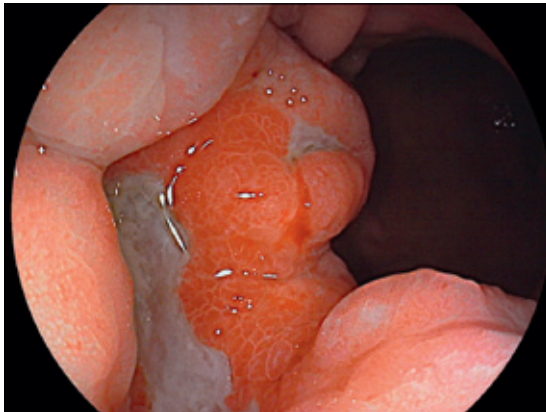

White light Stomach

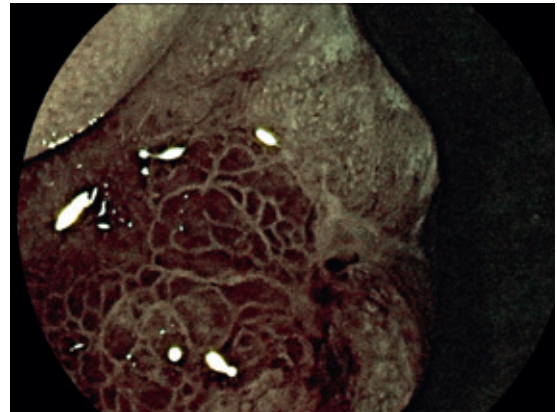

FICE0 + E-Zoom

## Dual Mode simultaneously display a FICE image and white light image on the same monitor

By having a dual view of a FICE image and white light image on the same monitor, you can collect more information for examination and diagnosis.

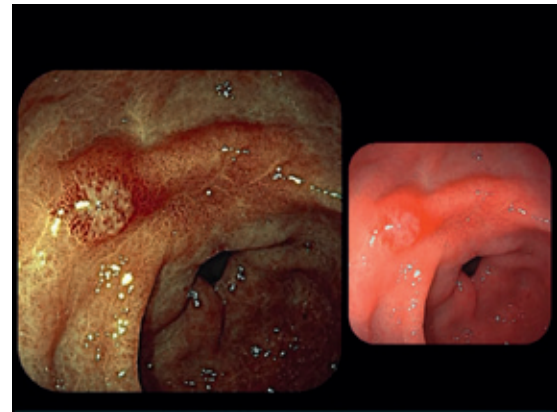

FICE1 Stomach

## Change the FICE preset pattern with the endoscope switch in real-time\*

Use the endoscope button to select up to three wavelength patterns from presets. You can switch quickly, moving to the next FICE image with a single push of a button which allows selection of the best pattern for the respective diagnosis.



Instant switching (switch patterns in rotation)

\*Only when using the EPX-4450HD

## ▶ ColoAssist II

Newly developed insertion portion for better insertion into the colon



### Gradual Stiffness

The flexibility of the insertion portion gradually increases toward the distal end. Gradual stiffness level is adjusted as comfortable for insertion. The modified gradual stiffness produce the softer distal end and harder operating side compared to previous type (ColoAssist). It is possible to transmit the insertion power to the tip of scope more effectively.

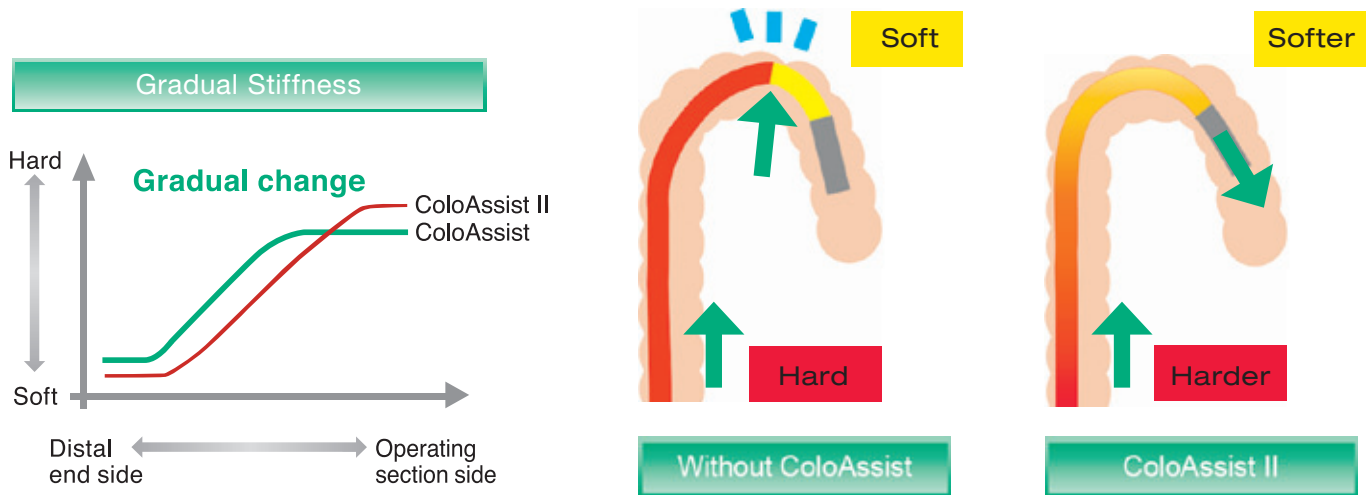

### Improved torque and force transmission and operation ability

By adopting ColoAssist II both torque and force transmission have been improved. Even when the tip of scope is located in the deep part of colon, the tip of scope can react sensitively. It's small diameter of 12.0 mm aims to produce better operability and reduce patient's discomfort.

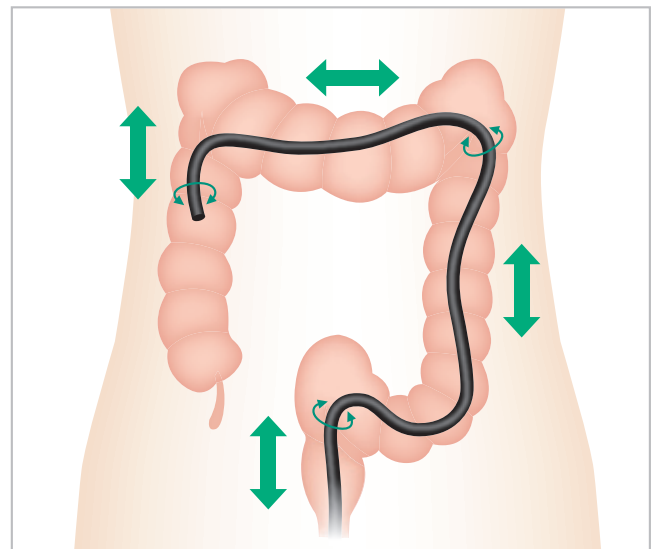

## Video Gastroscope ▶ EG-600WR

Product name: Video endoscope EG-600WR

GMDN: 38805

Generic name: Flexible video gastroduodenoscope



Field of view	140°
Observation range	2 ~ 100 mm
Bending capacity	UP 210° / DOWN 90° RIGHT 100° / LEFT 100°
Distal end diameter	9.2 mm
Flexible portion diameter	9.3 mm
Forceps channel diameter	2.8 mm
Working length	1,100 mm
Total length	1,400 mm
Water jet	Equipped

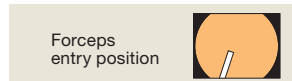
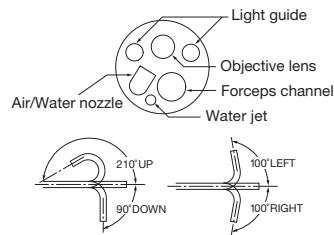

## Video Colonoscope ▶ EC-600WM / WI / WL

Product name: Video endoscope EC-600WM/EC-600WI/EC-600WL

GMDN: 36117

Generic name: Flexible video colonoscope



Field of view	140°
Observation range	2 ~ 100 mm
Bending capacity	UP 180° / DOWN 180° RIGHT 160° / LEFT 160°
Distal end diameter	12.0 mm
Flexible portion diameter	12.0 mm
Forceps channel diameter	3.8 mm
Working length	1,330/1,520/1,690 mm
Total length	1,630/1,820/1,990 mm
Water jet	Equipped

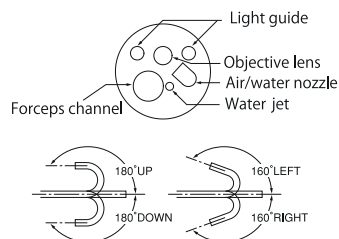

## High-quality image endoscope with Super CCD

The Fujifilm Super CCD provides high-resolution image quality and supports the detection of smallest lesions.



### ► Super CCD 590 series endoscopes

#### Video Gastroscope

#### ► EG-590WR

This endoscope is reasonably slim with a distal end of 9.6 mm, yet is equipped with adequate functions necessary for routine examinations. This is a high-definition standard endoscope. The air/water nozzle is redesigned to constantly secure a clear field of view, and its water filtering function is significantly improved.

Viewing direction	0° (Forward)
Field of view	140°
Observation range	6 - 100 mm
Distal end diameter	9.6 mm
Flexible portion diameter	9.3 mm
Bending capability	UP 210° / DOWN 90° RIGHT 100° / LEFT 100°
Working length	1,100 mm
Total length	1,400 mm
Forceps channel diameter	2.8 mm

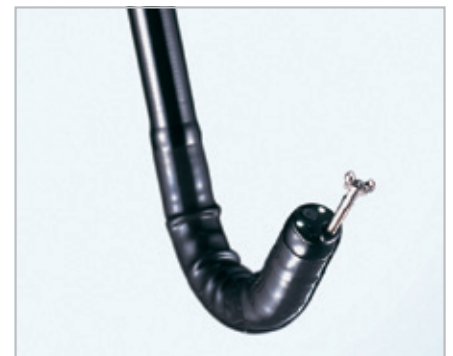
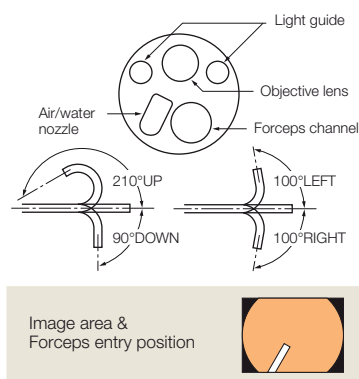

## Video Gastroscope – Optical Magnification

### ► EG-590ZW

EG-590ZW is a high-quality optical magnifying electronic endoscope for the upper G.I. tract. The optical magnification enhances the images for easier and closer observation. This endoscope has maximum optical magnification levels of up to 135 times when viewed on a 19 inch monitor and also an excellent field of view.

Viewing direction	0° (Forward)
Field of view	WD: 140° / TL: 55°
Observation range	WD: 6 - 100 mm / TL: 2 - 3mm
Distal end diameter	10.8 mm
Flexible portion diameter	9.8 mm
Bending capability	UP 210° / DOWN 90° RIGHT 100° / LEFT 100°
Working length	1,100 mm
Total length	1,400 mm
Forceps channel diameter	2.8 mm

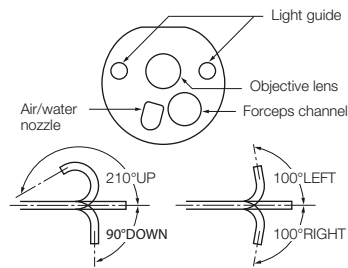
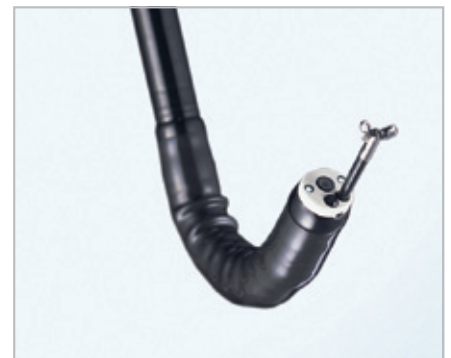

Image area & Forceps entry position



OPTICAL MAGNIFYING



## 590 series endoscopes provide high-quality image



Esophagus



Esophagus (Zoom)

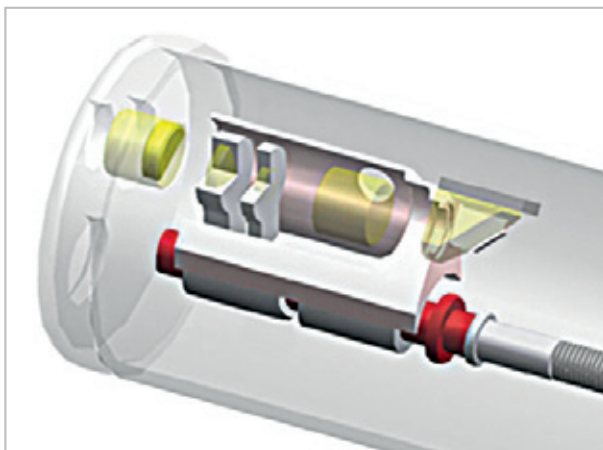

Optical Zoom structure

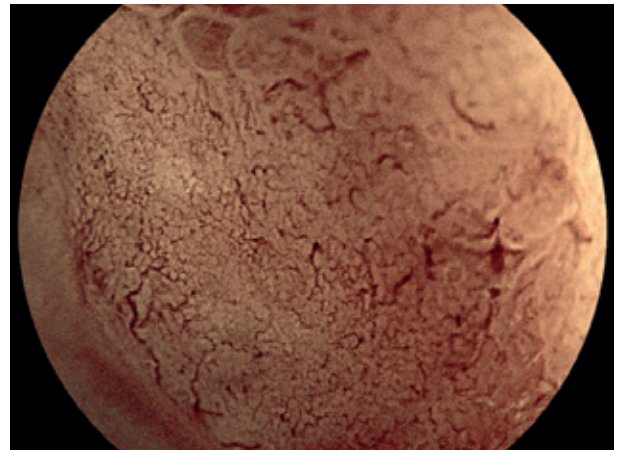

FICE0 Stomach (Zoom)

## Video Colonoscope

### ► EC-590WM4, EC-590WI4, EC-590WL4

These endoscopes for the lower G.I. tract routine examinations have an ultra-wide 140° field of view, a large 3.8 mm channel and also a water jet function which is effective for washing off mucus.

	WM4	WI4	WL4
Viewing direction	0° (Forward)		
Field of view	140°		
Observation range	3-100 mm		
Distal end diameter	12.8 mm		
Flexible portion diameter	12.8 mm		
Bending capability	UP 180° / DOWN 180° RIGHT 160° / LEFT 160°		
Working length	1,330 mm	1,520 mm	1,690 mm
Total length	1,630 mm	1,820 mm	1,990 mm
Forceps channel diameter	3.8 mm		

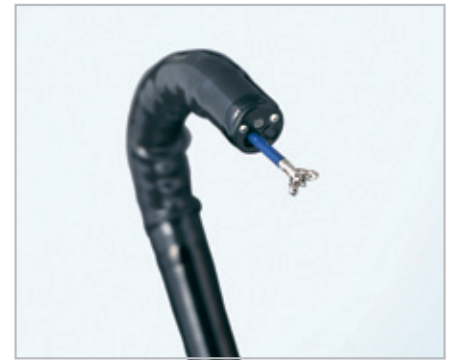
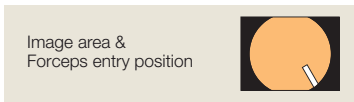
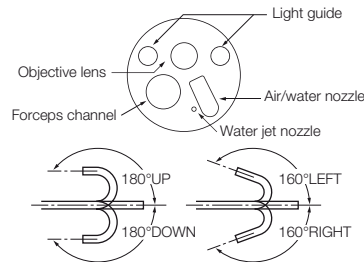

## Video Colonoscope – Optical Magnification

### ► EC-590ZW3/M, EC-590ZW3/L

These optical magnifying endoscopes for the lower G.I. tract have a water jet function which is effective for washing off mucus and securing a better field of view. These endoscopes have a wide variety of functions such as a large 3.8 mm forceps channel, optical magnifying function and water jet function.

	ZW3/M	ZW3/L
Viewing direction	0° (Forward)	
Field of view	WD: 140° / TL: 55°	
Observation range	WD: 6-100 mm / TL: 2-3 mm	
Distal end diameter	12.8 mm	
Flexible portion diameter	12.8 mm	
Bending capability	UP 180° / DOWN 180° RIGHT 160° / LEFT 160°	
Working length	1,330 mm	1,690 mm
Total length	1,630 mm	1,990 mm
Forceps channel diameter	3.8 mm	

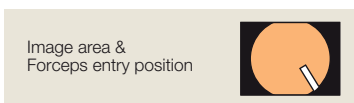
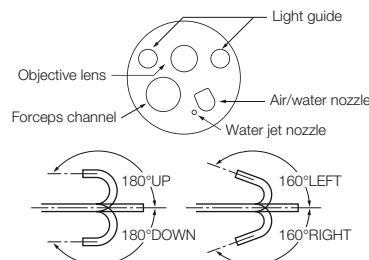

Colon (Zoom)

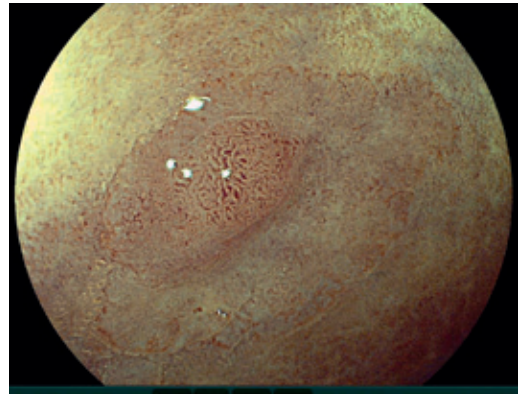

FICE8 Colon (Zoom)



▶ ColoAssist

Enhanced insertion capability and improved maneuverability

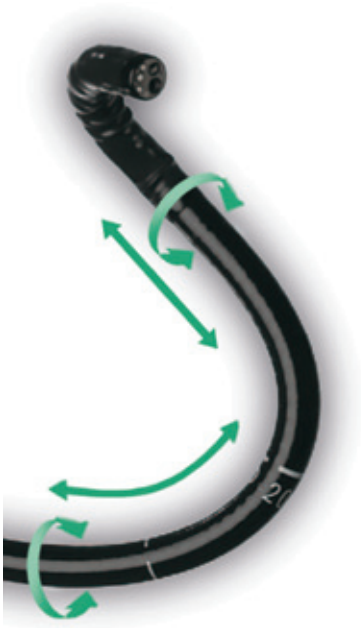

**Insertion section with gradual stiffness**

Insertion section with gradual flexibility enhances insertion capability.

**Precision up to the tip**

Fujifilm colonoscopes with ColoAssist convince by optimized force and torque transmission.

**Endoscopes with ColoAssist**

- ▶ EC-590ZW3/M, EC-590ZW3/L
- ▶ EC-590WM4/WI4/WL4
- ▶ EC-530WM3/WI3/WL3

**ColoAssist Technology**

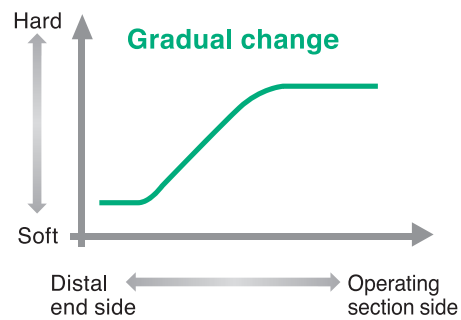

**Improved grip performance with newly-designed surface shape**

Ribbed surface prevents slipping and improves handling of the endoscope. Colonoscopy can be performed more easily and comfortably even in long examinations.



## ▶ Super CCD 580 series endoscopes

The newly designed 580 Super CCD realizes the high resolution even though small size image sensor.

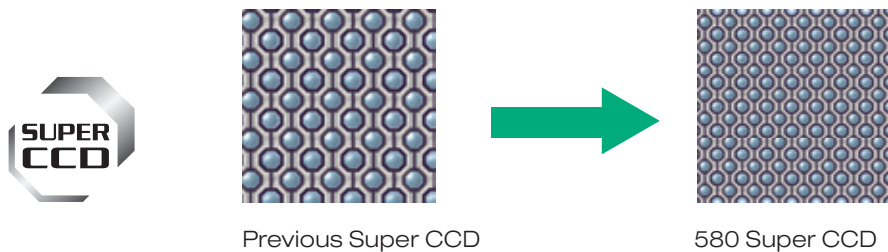

## ▶ High resolution slim colonoscopes EC-580RD/M, EC-580RD/L

Greater capabilities for observation and treatment.

These slim colonoscopes offer superior maneuverability and image quality.

## ▶ Smart Bend



**Smart Bend provides excellent maneuverability, observation and treatment by 210° up angulation, smaller bending radius and shorter rigid part**



Smart Bend features allow precise manipulation, enabling observation and treatment of areas usually difficult to approach, like overlapping or folded parts. Thus, the great bendability helps a wide range of procedures efficiently including screening, diagnosis and treatment such as EMR and ESD.



EC-580RD/M,L



EC-530MP,LP

## ▶ ColoAssist II



### Newly developed ColoAssist II especially for slim colonoscope for better insertion

These endoscopes adopt ColoAssist II specially designed for slim colonoscope. These slim colonoscopes having the special soft insertion tube can support various applications including those for pediatrics or patients suffering IBD. The diameter of the flexible portion has been reduced to 10.5 mm in consideration of mitigating discomfort to patients.

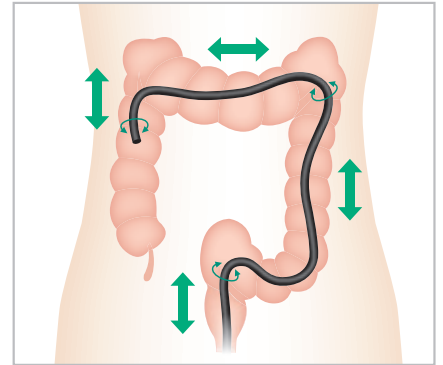

## ▶ 580 Super CCD



### High resolution image even though slim type colonoscope

The new Super CCD and high performance optical system ensures high quality images. Together with the FICE providing vivid images, such features support various procedures including detection and treatment of lesions.

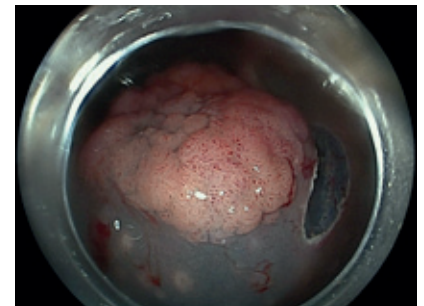
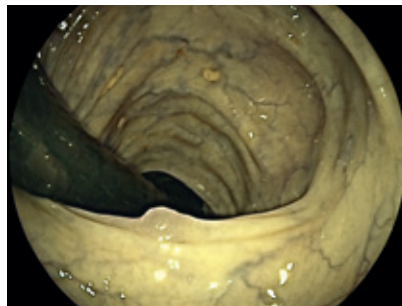

### Video Colonoscope – Slim Type

#### ▶ EC-580RD/M, EC-580RD/L

Field of view	140°
Observation range	3-100 mm
Bending capability	UP 210° / DOWN 160° RIGHT 160° / LEFT 160°
Distal end diameter	9.8 mm
Flexible portion diameter	10.5 mm
Forceps channel diameter	3.2 mm
Working length	1,330 / 1,690 mm
Total length	1,630 / 1,990 mm
Water jet	Equipped

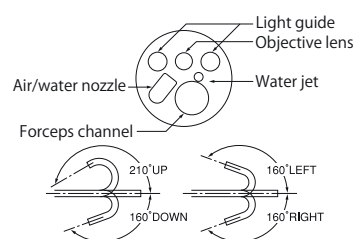
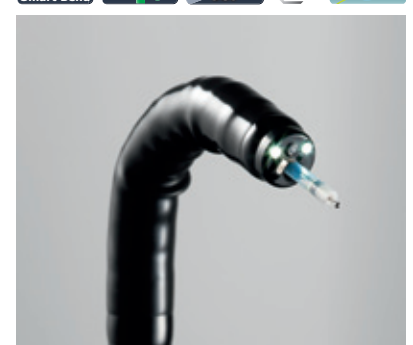

Image area & forceps entry position



New therapeutic Double Balloon Endoscope with 3.2 mm diameter forceps channel – ideal for various procedures

High-resolution therapeutic Double Balloon Endoscope EN-580T

## **DOUBLE BALLOON ENDOSCOPY**



▶ 3.2 mm forceps channel



A large forceps channel of 3.2 mm in diameter for efficient treatment

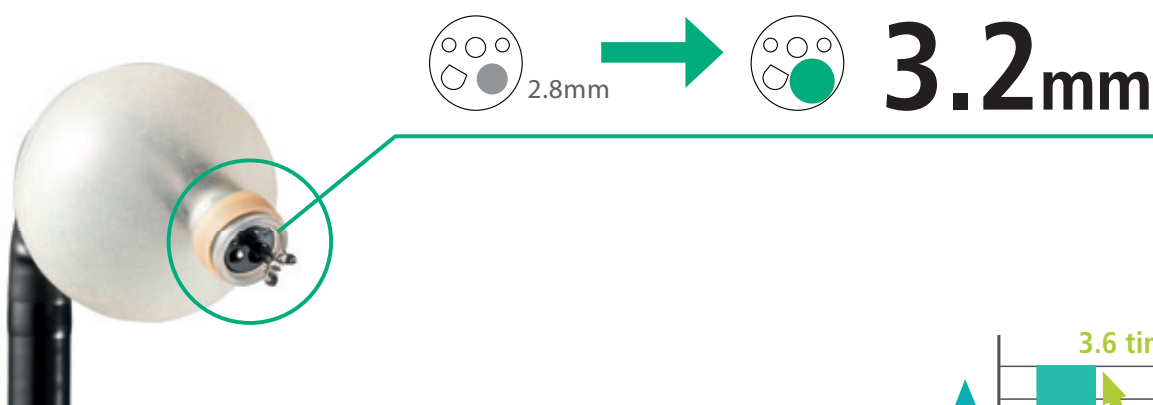

The 3.2 mm diameter forceps channel providing greater suction performance than that of conventional models.

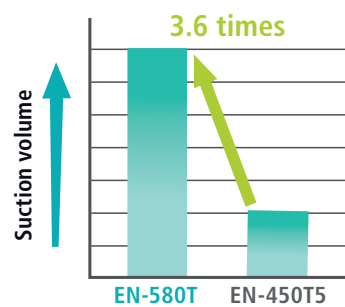

With  $\Phi 2.4$  device

\*According to Fujifilm data

The 3.2 mm diameter forceps channel suits various procedures like hemostasis and balloon dilation. As it enables blood or mucus to be aspirated while a therapeutic device is inserted, quicker hemostasis is possible. The large forceps channel is also intended for easier insertion and removal of a balloon catheter before and after dilation of structures.

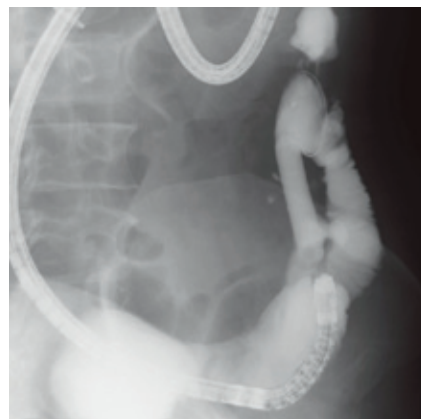
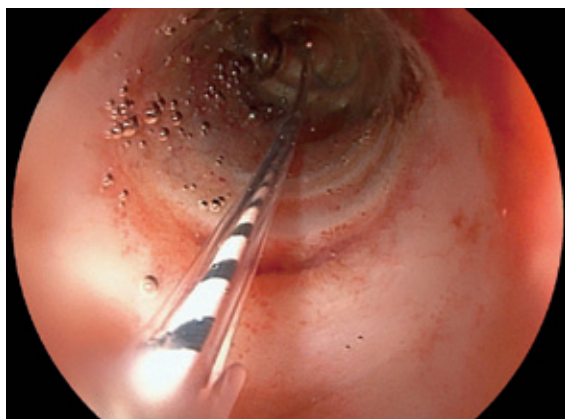

## ▶ 580 Super CCD with Close Focus



### Superior image quality in close focus for more detailed diagnosis

The new high-resolution Super CCD ensures vivid and high quality images, while the newly designed Close Focus optics enhances the possibility of obtaining more detailed images, thus allowing the compilation of a wide range of data necessary for diagnosis. Used in combination with FICE, it provides better contrast for vascular and surface patterns in close focus, emphasizing the structure of tissue aspects and vessels.



White light image of intestinal villi

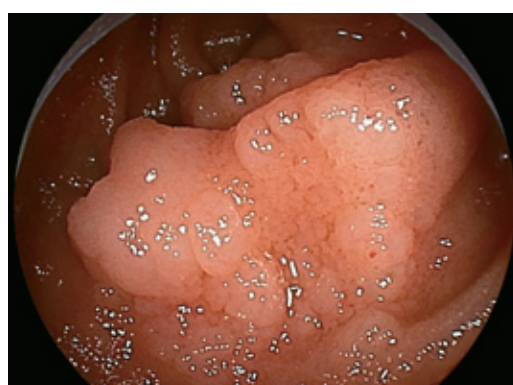

FICE image of intestinal villi

## ▶ One-touch connector and relocated balloon air feed inlet

### Newly designed one-touch connector and relocated balloon air feed inlet for better operability

The balloon air feed inlet has been relocated from the control portion to the connector portion, creating a better examination environment. Also, a one-touch type connector especially designed for the balloon air feed inlet on the endoscope is provided, making the preparation simpler.

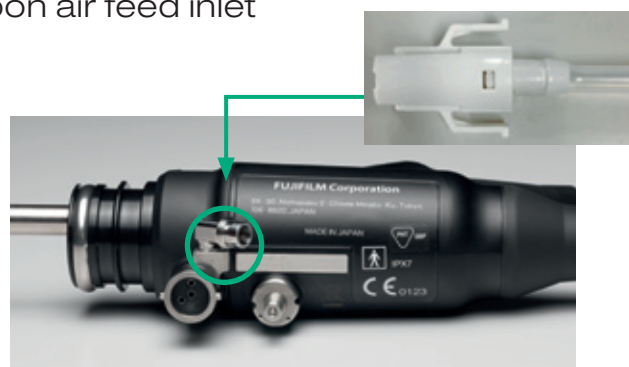



## Enteroscope – Treatment Type

### ► EN-580T

Viewing direction	0° (Forward)
Field of view	140°
Observation range	2-100 mm
Distal end diameter	9.4 mm
Flexible portion diameter	9.3 mm
Bending capability	UP 180° / DOWN 180° RIGHT 160° / LEFT 160°
Working length	2,000 mm
Total length	2,300 mm
Forceps channel diameter	3.2 mm

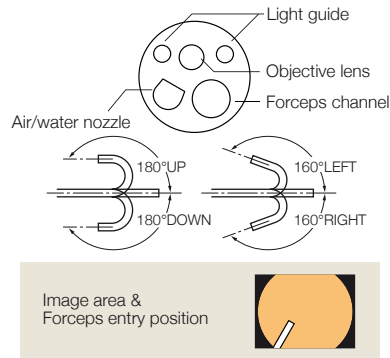

### ► Overtube TS-13140

Overtube model	TS-13140	TS-13101
Outer diameter	13.2 mm	13.2 mm
Total length	1,450 mm	950 mm
Applicable endoscope	EN-580T	EC-450BI5

### BS-2

Outer diameter	35 mm
----------------	-------

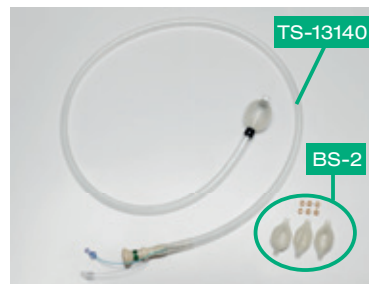

### ► Balloon Setting Tools ST-05B and ST-10

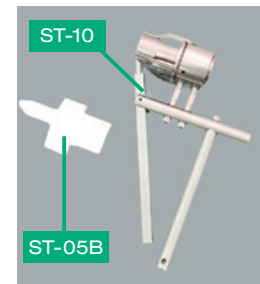

### ► Balloon controller PB-20

Power	35 W
Maximum flow rate of pump	170 ml ± 50 ml / 10 sec
Dimensions	350(W)x130(H)x420(D)mm
Weight	10kg (Main unit), 0.4kg (Remote switch)
Balloon air outlets	2 points (for endoscopes; for overtube)



## Colonoscope – Standard Type

### ► EC-450BI5

Using balloons, the endoscope is stabilized in the intestinal tract, which leads to better observation and treatment of lesions.

Viewing direction	0° (Forward)
Field of view	140°
Observation range	3-100 mm
Distal end diameter	9.4 mm
Flexible portion diameter	9.3 mm
Bending capability	UP 180° / DOWN 180° RIGHT 160° / LEFT 160°
Working length	1,520 mm
Total length	1,820 mm
Forceps channel diameter	2.8 mm

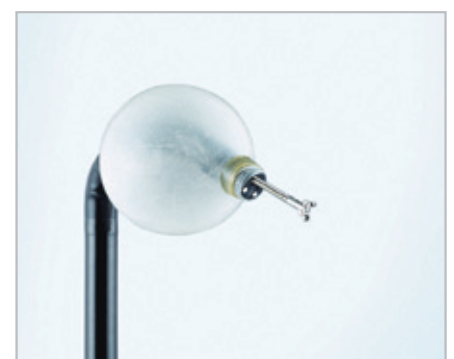
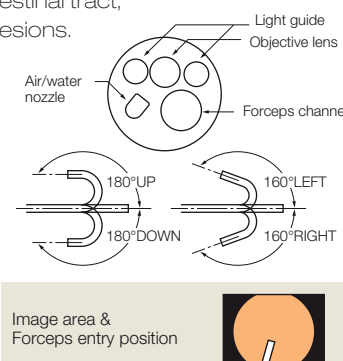

## The new high-definition standard in endoscopy

The Fujifilm high-definition system represents the standard in digital endoscopy – in terms of both technology and cost-efficiency. It enables us to provide you with endoscopy equipment that is more affordable than ever before. At the heart of the system is the EPX-2500 video processor, which delivers images in high definition without loss in quality.





## ▶ The EPX-2500 video processor High definition in everyday work

The EPX-2500 combines convenient operation with high-resolution images that have optimal illumination. The digital video output (DVI) of the EPX-2500 produces images in high definition without loss of quality. Furthermore, the processor is equipped with a range of functions.

- ▶ Two ports for connecting Fujifilm 200 series and 530 series endoscopes
- ▶ Integrated xenon light source for bright, uniformly illuminated images
- ▶ Quick and simple operation
- ▶ Picture-in-picture function with freeze mode for live-display
- ▶ Better imaging of blood vessels
- ▶ 2x zoom for instant enlargement



## ▶ High-quality 530 series endoscopes cover screening, diagnosis and treatment

530 series endoscopes feature high-quality endoscopes which serve various kinds of examination and diagnosis. The entire upper and lower G.I. including ultra-slim endoscopes.

## Video Gastroscope – Transnasal Type

### ► EG-530NW

The ultra-slim gastroscope with a distal end diameter of 5.9 mm is made possible by Fujifilm's proprietary microfabrication technology and offers a wide field of view with high-resolution imaging similar to that obtainable with transoral gastroscopes. The flexible gastroscope is ideal for transnasal insertion and provides the operator with highly visible endoscopic images while reducing patient discomfort.

Viewing direction	0° (Forward)
Field of view	140°
Observation range	4-100 mm
Distal end diameter	5.9 mm
Flexible portion diameter	5.9 mm
Bending capability	UP 210° / DOWN 90° RIGHT 100° / LEFT 100°
Working length	1,100 mm
Total length	1,400 mm
Forceps channel diameter	2.0 mm

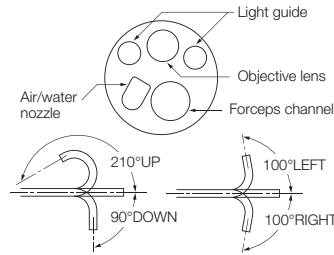

Image area & Forceps entry position



140° WIDE VIEW

TRANSNASAL

ULTRA-SLIM  
5.9 mm

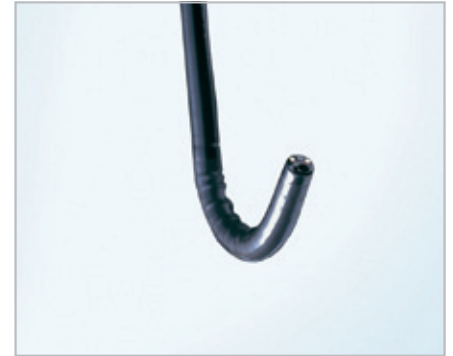

## Video Gastroscope – Transnasal Type

### ► EG-530NP

EG-530NP slimmed down its endoscope to the utmost and realized a 4.9 mm distal end (5.1 mm in the flexible portion), immensely improving the transnasal insertion capability. This transnasal endoscope is also equipped with dual light guides and a 2.0 mm forceps channel.

Viewing direction	0° (Forward)
Field of view	120°
Observation range	3-100 mm
Distal end diameter	4.9 mm
Flexible portion diameter	5.1 mm
Bending capability	UP 210° / DOWN 120°
Working length	1,100 mm
Total length	1,460 mm
Forceps channel diameter	2.0 mm

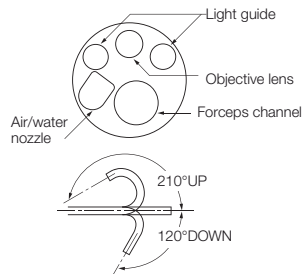

Image area & Forceps entry position



TRANSNASAL

ULTRA-SLIM  
4.9 mm



## Video Gastroscope

### ► EG-530WR

The EG-530WR with a wide field of view of 140° provides exceptional visualization. With the forceps channel of 2.8 mm, it is a standard endoscope producing high-quality images, which is highly suited for biopsies and treatment.

Viewing direction	0° (Forward)
Field of view	140°
Observation range	4-100 mm
Distal end diameter	9.4 mm
Flexible portion diameter	9.3 mm
Bending capability	UP 210° / DOWN 90° RIGHT 100° / LEFT 100°
Working length	1,100 mm
Total length	1,400 mm
Forceps channel diameter	2.8 mm

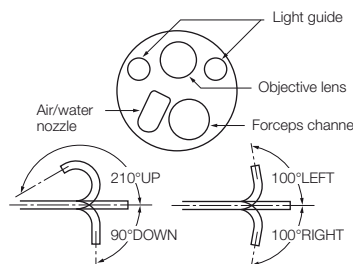

Image area & Forceps entry position



## Video Gastroscope – Slim Type

### ▶ EG-530FP

EG-530FP is a slim endoscope for the upper G.I. tract having a forceps channel of 2.8 mm diameter and a distal end of 8.5 mm. Observation capability has been increased with a wide field of view of 140° and Fujifilm's Super CCD technology.

Viewing direction	0° (Forward)
Field of view	140°
Observation range	3-100 mm
Distal end diameter	8.5 mm
Flexible portion diameter	8.5 mm
Bending capability	UP 210° / DOWN 90° RIGHT 100° / LEFT 100°
Working length	1,100 mm
Total length	1,400 mm
Forceps channel diameter	2.8 mm

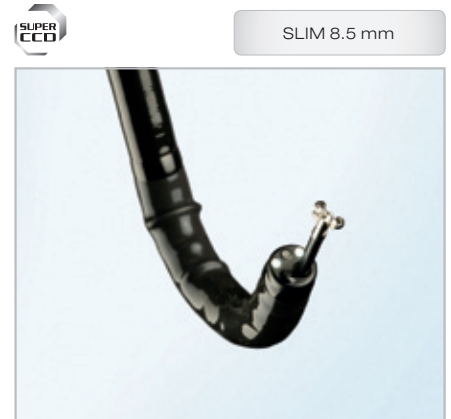
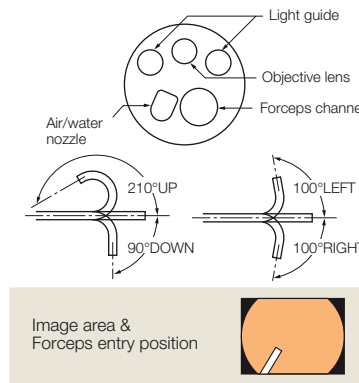

## Video Gastroscope – Treatment Type

### ▶ EG-530CT

With the forceps channel as wide as 3.8 mm, EG-530CT's distal end is as slim as 10.8 mm in diameter. To support therapeutic interventions, a water jet function is incorporated.

Viewing direction	0° (Forward)
Field of view	140°
Observation range	3-100 mm
Distal end diameter	10.8 mm
Flexible portion diameter	10.8 mm
Bending capability	UP 210° / DOWN 90° RIGHT 100° / LEFT 100°
Working length	1,100 mm
Total length	1,400 mm
Forceps channel diameter	3.8 mm

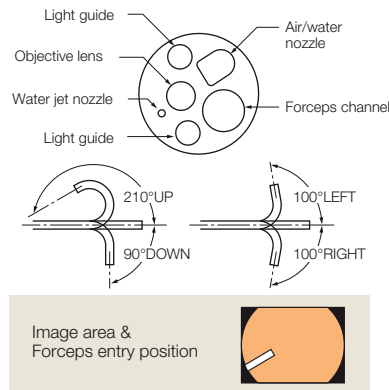

## Video Gastroscope – Treatment Type

### ▶ EG-530D

EG-530D is an endoscope for treatment of the upper G.I. tract, having two forceps channels, 3.8 mm and 2.8 mm, and a distal end as slim as 11.5 mm. Water jet function is also incorporated for various treatment methods during endoscopy.

Viewing direction	0° (Forward)
Field of view	140°
Observation range	3-100 mm
Distal end diameter	11.5 mm
Flexible portion diameter	11.5 mm
Bending capability	UP 210° / DOWN 90° RIGHT 100° / LEFT 100°
Working length	1,090 mm
Total length	1,405 mm
Forceps channel diameter	3.8 mm / 2.8 mm

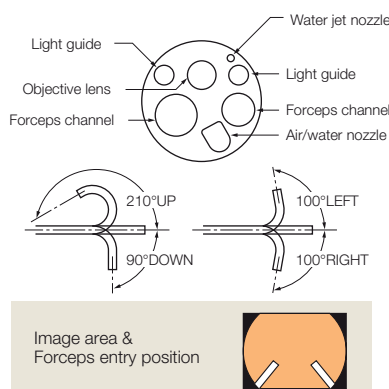

## Video Duodenoscope – Treatment Type ▶ ED-530XT, ED-530XT8

The structure of the distal end, bending portion and flexible portion is changed for improved operability during examination and treatment.

Viewing direction	98° (8° rearward)
Field of view	100°
Observation range	4-60 mm
Distal end diameter	13.1 mm
Flexible portion diameter	11.5 mm
Bending capability	UP 130° / DOWN 90° RIGHT 110° / LEFT 90°
Working length	1,250 mm
Total length	1,550 mm
Forceps channel diameter	4.2 mm

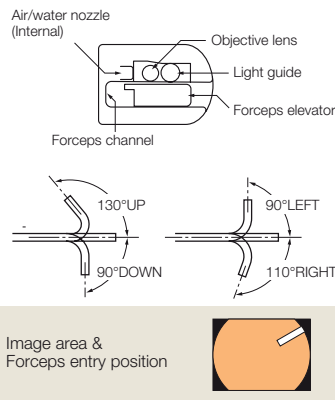

### Improved operability

#### Easy to catch the papilla

The objective lens arrangement and bending performance have been properly arranged to catch the papilla easily from various endoscope positions.

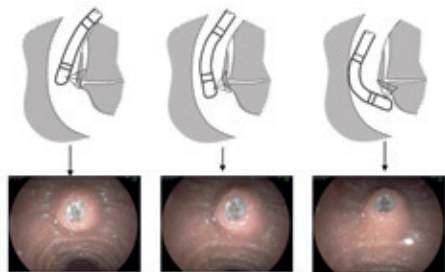

#### Improved insertion capability of ERCP accessories into the papilla



Newly designed forceps elevator has been applied to enhance accessory control more precisely and securely, facilitating easier ERCP treatment.

#### Easy operability of the insertion portion

The stiffness of the insertion portion has been improved for easier stomach stretching and insertion capability.

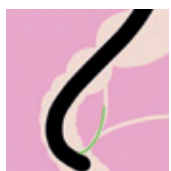

### Excellent image quality

Fujifilm's Super CCD, which has been exclusively developed for the endoscope, is built-in, providing clear images.

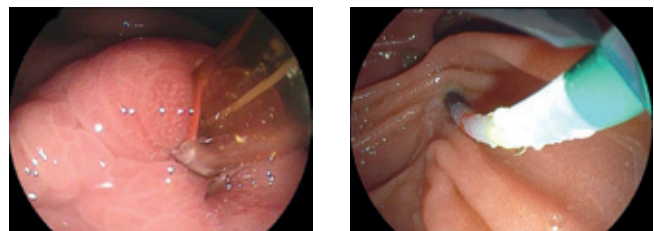

### Improved cleaning and disinfection

#### Removable distal end cap\*

The ED-530XT8 is equipped with a disposable distal end cap. It enables brushing all channels and helps to improve the hygienic environment.

\*ED-530XT8 only



#### Covered tilt-up mechanism

A covered tilt-up mechanism of the forceps elevator maintains the elevator wire clean without any additional cleaning procedure.



## Video Colonoscope

### ► EC-530WM3, EC-530WI3, EC-530WL3

With a wide field of view of 140°, these lower G.I. tract endoscopes have a greater resolution. The newly ColoAssist design facilitates the insertion capability.

	WM3	WI3	WL3
Viewing direction	0° (Forward)		
Field of view	140°		
Observation range	3-100 mm		
Distal end diameter	12.8 mm		
Flexible portion diameter	12.8 mm		
Bending capability	UP 180° / DOWN 180° RIGHT 160° / LEFT 160°		
Working length	1,330 mm	1,520 mm	1,690 mm
Total length	1,630 mm	1,820 mm	1,990 mm
Forceps channel diameter	3.8 mm		

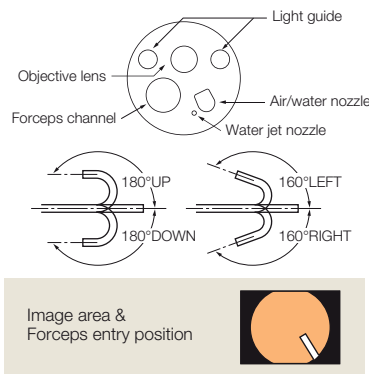

## Video Colonoscope – Slim Type

### ► EC-530MP, EC-530LP

These are slim-type colonoscopes with the distal end of 11.0 mm. While these two slimmed-down endoscopes have improved insertability, they retain a 3.2 mm forceps channel to accommodate various treatment methods.

	MP	LP
Viewing direction	0° (Forward)	
Field of view	140°	
Observation range	3-100 mm	
Distal end diameter	11.0 mm	
Flexible portion diameter	11.1 mm	
Bending capability	UP 180° / DOWN 180° RIGHT 160° / LEFT 160°	
Working length	1,330 mm	1,690 mm
Total length	1,630 mm	1,990 mm
Forceps channel diameter	3.2 mm	

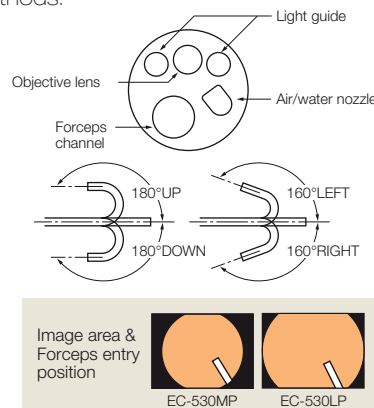

SLIM 11.0 mm



## Video Colonoscope – Treatment Type

### ► EC-530DM, EC-530DL

These lower G.I. tract endoscopes have two forceps channels (3.8 mm and 2.8 mm), especially useful for treatment such as EMR.

	DM	DL
Viewing direction	0° (Forward)	
Field of view	140°	
Observation range	3-100 mm	
Distal end diameter	12.8 mm	
Flexible portion diameter	12.8 mm	
Bending capability	UP 180° / DOWN 180° RIGHT 160° / LEFT 160°	
Working length	1,330 mm	1,690 mm
Total length	1,645 mm	2,005 mm
Forceps channel diameter	3.8 mm / 2.8 mm	

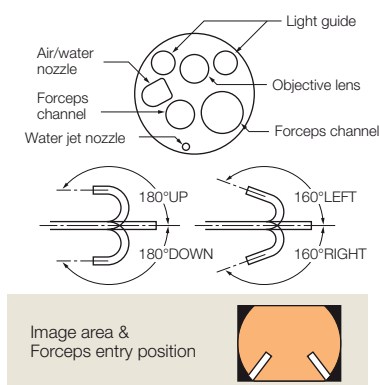

DUAL CHANNEL



## Video Colonoscope

### ► EC-530FI, EC-530FL

These super wide-angle standard colonoscopes offer a large 3.8 mm working channel inside a slim 12.8 mm outside diameter. An ultra-wide 140° field of view enhances the image quality. These colonoscopes also offer a wider observation range from 3-100 mm. In addition, an integrated forward water jet allows for lavage in clinical situations.

	FI	FL
Viewing direction	0° (Forward)	
Field of view	140°	
Observation range	3-100 mm	
Distal end diameter	12.8 mm	
Flexible portion diameter	12.8 mm	
Bending capability	UP 180° / DOWN 180° RIGHT 160° / LEFT 160°	
Working length	1,520 mm	1,690 mm
Total length	1,820 mm	1,990 mm
Forceps channel diameter	3.8 mm	

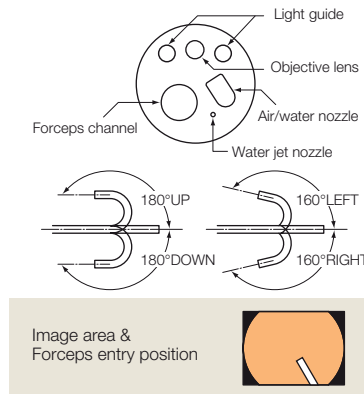

## Video Sigmoidoscope

### ► ES-530WE

ES-530WE is a sigmoidoscope of an effective length of 790 mm. The forceps channel diameter is 3.8 mm, and is equipped with water jet function.

Viewing direction	0° (Forward)
Field of view	140°
Observation range	3-100 mm
Distal end diameter	12.8mm
Flexible portion diameter	12.8mm
Bending capability	UP 180° / DOWN 180° RIGHT 160° / LEFT 160°
Working length	790mm
Total length	1,090mm
Forceps channel diameter	3.8mm

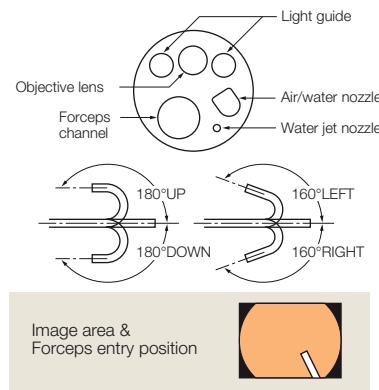

### ► Short-type ST hoods

Prevents the surgical field of view being blocked by mucosa and keeps it clear during the endoscopic treatment. Helps to perform safer and more efficient ESD and POEM.

DH-28GR	11.8 mm	7.0 mm	8.0 mm	2	Without	EG-590WR, EG-530WR, EC-580RD M,L
DH-29CR	13.0 mm	7.0 mm	8.0 mm	2	Without	EG-590ZW, M, L, EC-530MP, EC-530LP
DH-30CR	14.8 mm	7.0 mm	8.0 mm	2	Without	EC-600WM, WI, WL, EC-590WM4, WI4, WL4, EC-590ZW3 M/L, EC-530WM3, WI3, WL4

### Features of short-type ST hoods

Shorter distance from the endoscope tip and wider inner diameter of the distal end than current hoods, enhancing visibility. Two drain equipped. Easier insertion of accessories with the guide ditch eliminated.

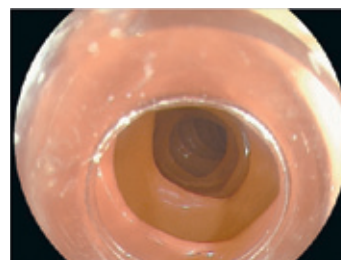

## ► FlushKnife BT / FlushKnife

Aimed at achieving enhanced usability ideal for all physicians from ESD trainees to skilled practitioners.

# FlushKnife



### Water jet system maintains the sharpness of the knife

The water jet system keeps the tip of the knife clean by washing off debris and lesion tissue adhering to the tip, thereby maintaining the sharpness of the knife throughout the treatment.

### One knife covers from marking to arrest of bleeding, achieving high versatility

One knife carries out procedures including marking, incision, dissection and arrest of bleeding. The high versatility improves operation and cost efficiencies.



Marking

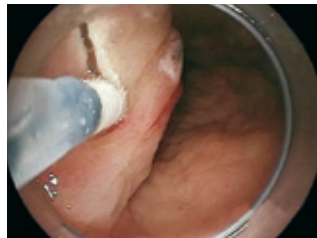

Mucosal incision



Submucosal dissection



Arrest of bleeding

### The tip is designed to enhance safety and treatment capability

FlushKnife BT has a ball tip, which produces good traction, enabling the target tissue to be dissected smoothly. The ball tip touches a wider part of the tissue and arrests bleeding more efficiently.

Safer and more efficient treatment is achieved by using the protruding knife length best suited for each treatment area.

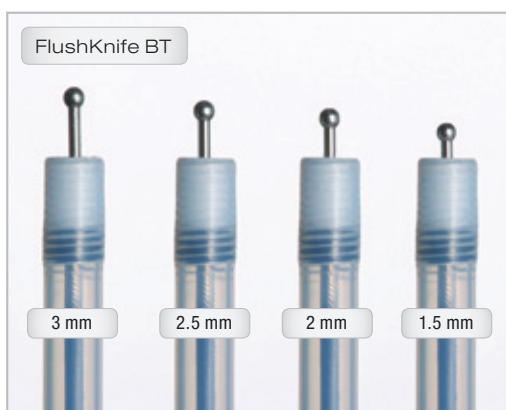

## ► EUS Tower – all-in-one stack concept

Years of research and development to reduce patient discomfort and improve operator efficiency during endoscope examinations led to the development of Sonart, the integration of ultrasonographic diagnosis and endoscopy systems.

For a more accurate diagnosis, advanced image processing technology integrates improved endoscope maneuverability and insertion capability. The compact, one-cart system supports various applications.



# Sonart



## Flexible image display and switching

Keyboard operation facilitates smooth examinations and allows switching among an ultrasound image, an endoscopic image, and a picture-in-picture image with patient's history images.

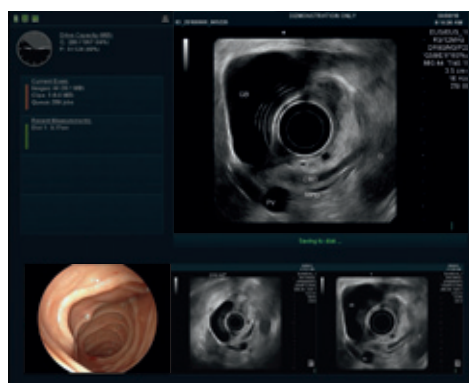

Picture-in-picture image

Patient's history image

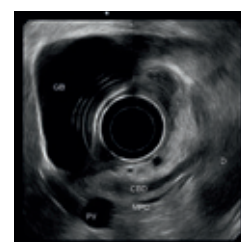

Ultrasound image

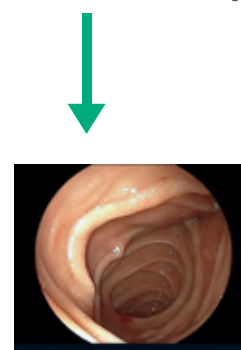

Endoscopic image



## ZONE Sonography™ technology ensures high-quality images

ZONE Sonography™ technology defines conventional wisdom in ultrasonography. The technology delivers wide ultrasound beams and quickly acquires large amounts of echo data in sizeable zones. Split-second data acquisition allows highly advanced image processing.

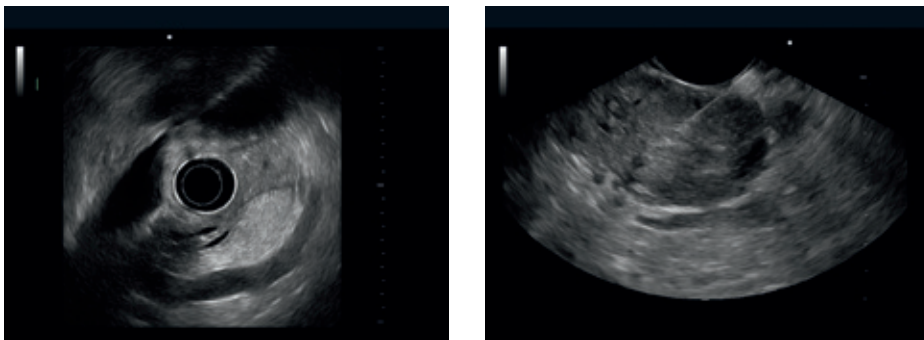
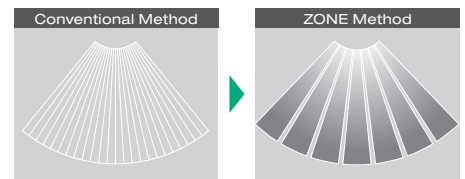

## Sound Speed Correction technology improves image resolution

Advanced image processing technology estimates the optimal speed of ultrasound travelling through the body (sound speed) and constructs images.

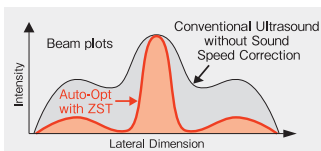

### What is Sound Speed Correction?

The resolution in the lateral dimension deteriorates due to a difference in sound speed. By correcting this and carrying out optimization, the resolution in the lateral dimension is improved.

1450 m/s ATS Phantom

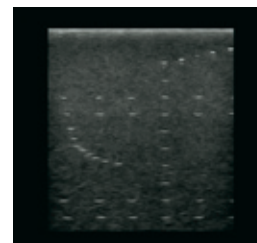

Imaged at 1540 m/s before Sound Speed Correction

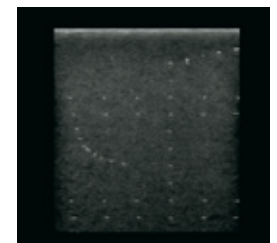

Imaged at 1450 m/s after Sound Speed Correction

## Display quality images in different modes

Technologies developed in the field of ultrasonographic diagnosis improve the quality of ultrasound images. Images created from advanced image processing enable the use of appropriate modes for your setting.

### C mode

The Color Doppler function obtains hemodynamic information in disease areas and helps you locate the observation site and vascular structures.

SU-8000 Scanning modes; C mode, Power Doppler, Pulse wave, B mode, M mode

### Frequency switching

A wide range of frequencies (5, 7.5, 10, and 12 MHz) helps to delineate clear C mode images of the regions.

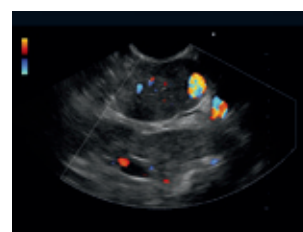

CFM mode

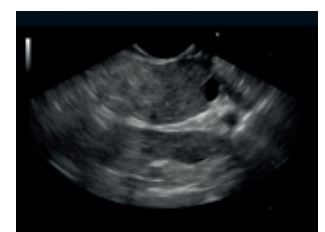

B mode

## ▶ Ultrasonic endoscopes

### EG-530UR2, EG-530UT2

EG-530UR2 and EG-530UT2 endoscopes combine Fujifilm's high-quality endoscope features with the most advanced ultrasound technology, to create an unsurpassed diagnostic and treatment system.

#### Excellent insertion capability

Newly designed structure of flexible portion improves insertion capability. The tip with a small bending radius allows better observation.



#### Consideration of the safety of fine needle aspiration

Dotted yellow guidelines are visualized on the monitor to ensure the safety of paracentesis.

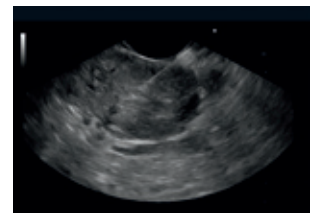

#### High-quality endoscopic image

Equipped with the Super CCD, this ultrasound endoscope offers bright, vivid, high-resolution image.

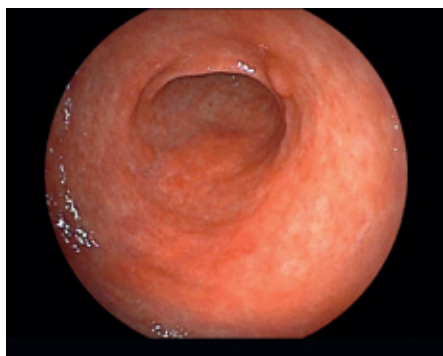

EG-530UR2

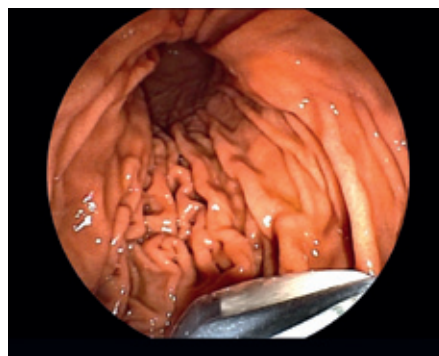

EG-530UT2

#### In pursuit of balloon operability

An air/water and suction button inflates water to the balloon and deflates water from the balloon.



## Radial Scan Ultrasound Video Endoscope

### ▶ EG-530UR2

With a slim distal end of 11.4 mm and excellent bending capabilities, the EG-530UR2 allows physicians to perform endoscopic ultrasonography in a similar way to conventional endoscopy.

Viewing direction	0° (Forward)
Field of view	140°
Observation range	3-100 mm
Distal end diameter	11.4 mm
Flexible portion diameter	11.5 mm
Bending capability	UP 180° / DOWN 90° RIGHT 100° / LEFT 100°
Working length	1,250 mm
Total length	1,550 mm
Forceps channel diameter	2.2 mm

Scanning mode	Color Doppler, Power Doppler, PW Doppler, B mode, M mode
Scanning method	Electronic radial scan
Scanning angle	360°
Frequency	5 Mhz / 7.5 Mhz / 10 Mhz / 12 Mhz
Contact method	Balloon method, degassed water congestion method, contacting method

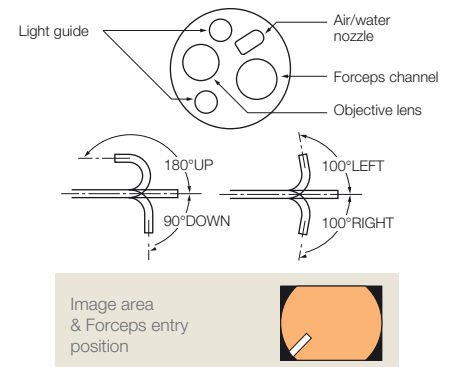

## Convex Scan Ultrasonic Video Endoscope

### ▶ EG-530UT2

With its forceps channel elevator function, the distal end of EG-530UT2 improves the injection performance of the puncture needle. It also has a large channel which enables various treatment accessories to be inserted. With excellent bending capabilities, the EG-530UT2 provides greater flexibility in treatment.

Viewing direction	Forward oblique 40°
Field of view	140°
Observation range	3-100 mm
Distal end diameter	13.9 mm
Flexible portion diameter	12.1 mm
Bending capability	UP 160° / DOWN 160° RIGHT 120° / LEFT 120°
Working length	1,250 mm
Total length	1,550 mm
Forceps channel diameter	3.8 mm

Scanning mode	Color Doppler, Power Doppler, PW Doppler, B mode, M mode, THI
Scanning method	Electronic convex scan
Scanning angle	110° (Combination with SU-7000) 124° (Combination with SU-8000)
Frequency	5 Mhz / 7.5 Mhz / 10 Mhz / 12 Mhz
Contact method	Balloon method, degassed water congestion method, contacting method

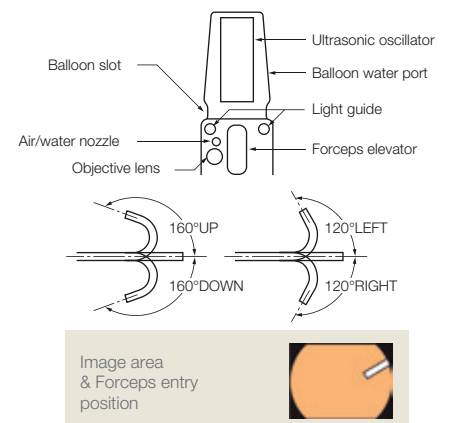

► The CO<sub>2</sub> insufflator GW-1

Faster resorption of insufflated CO<sub>2</sub> for shorter examinations

Insufflated CO<sub>2</sub> reduces the bloated sensation for patients and the pain in drawn-out procedures.

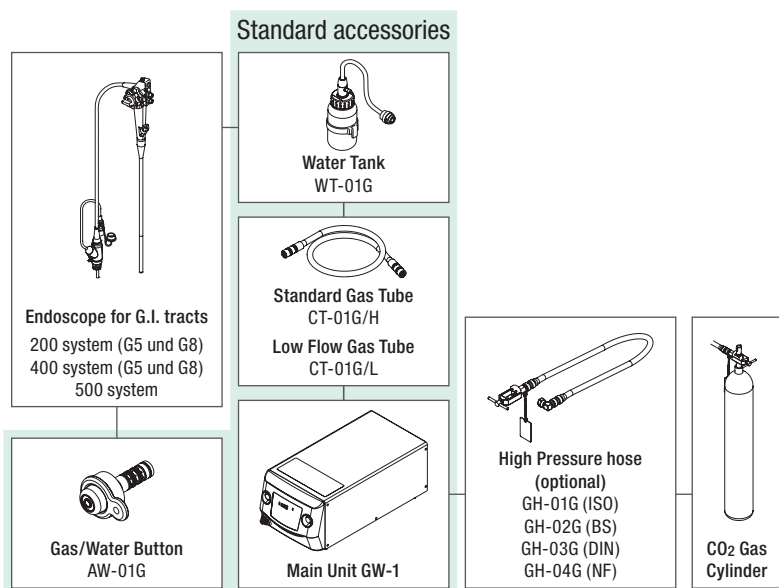

Example of System Configuration

► Water pump JW-2

Specially designed for advanced endoscopic examination

Proprietary piping technology enables water flow to be quickly stopped. One-liter water bottle enables prolonged water use and minimizes the need for constant refilling.



► SYNAPSE-NX

Complete documentation and imaging for endoscopy

# SYNAPSE NX

SYNAPSE-NX is a system for increasing the efficiency of the endoscopy workflow and performing inspection duties safely and with certainty. This set-up is connected with systems such as HIS, medical monitors and scope reprocessing machines. Synapse facilitates smooth inspection organization and reduces the time and effort in your daily activities. Moreover, SYNAPSE-NX is independent from the manufacturer of an endoscope.



### Automatic storage of reprocessing protocols

Automatically receive full protocols from a wide variety of different disinfection machines and link them to the patient. Keep control with the integrated disinfection management module – for complete traceability.

► EPX-4450HD integrates into the hospital network environment with DICOM interfaces

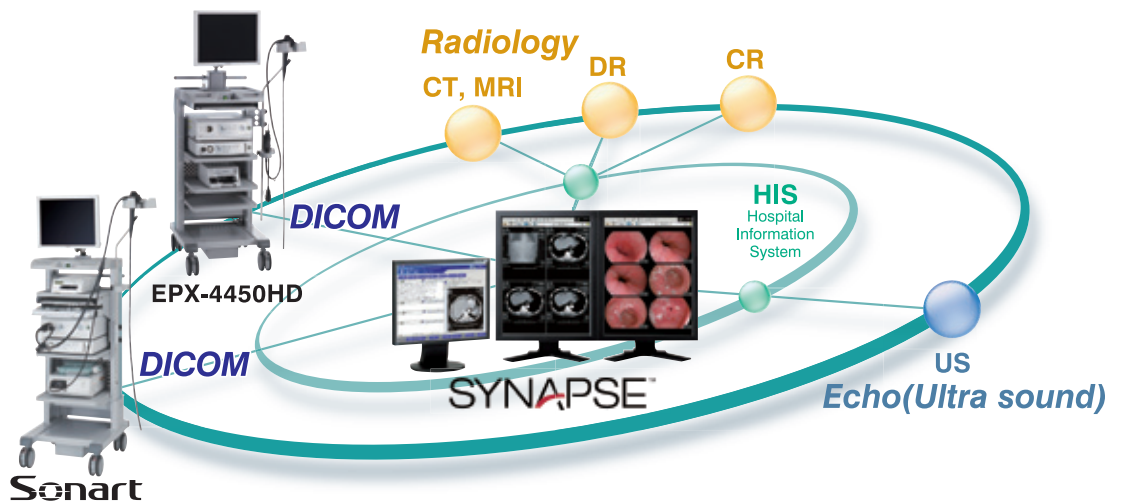

## Video Processor

### ▶ EPX-4450HD



#### VP-4450 HD Processor

Digital output	HD-SDI: HDTV 1080i (2ch) DVI (Digital Visual Interface): 1280 x 1024 p Ethernet: 100 / 10 Base	
Analog output	RGB: 1280 x 1024 p SDTV (120 V/NTSC, 230 V/PAL): RGB Y/C, Composite	
Color adjustment	Brightness, Red, Green, Blue, R-Hue, Chroma; 9 steps	
Detail	Hi, Lo; 9 steps	
Contrast (gamma)	3 steps	
Hyper-Sharpness	Hi, Mid, Lo, Off	
Color emphasis	Hi, Mid, Lo, Off	
FICE	Flexible spectral imaging Color Enhancement 10 presets	
Iris	Average / Peak / Auto	
Image storage	CF Card	
Power rating	120 V 60 Hz 0.8 A	230 V 50 Hz 0.5 A
Dimensions (W x H x D)	390 x 105 x 460 mm	
Weight	9.5 kg	
DICOM	MWL, Store	

#### XL-4450 Light source

Lamp rated value	Main Lamp: 300 W Xenon lamp LMP-002 Emergency Lamp: 75 W Halogen lamp	
Light control	Automatic light control	
Lamp cooling method	Forced air cooling	
Air supply pump	High, Mid, Lo, Off	
Light save	On, Off	
Transmitted illumination	On, Off	
Power rating	120 V 60 Hz 3.3 A	230 V 50 Hz 1.7 A
Dimensions (W x H x D)	390 x 155 x 450 mm	
Weight	15 kg	

## Video Processor

### ▶ EPX-2500



Digital output	DVI (Digital Visual Interface): 1024 x 768 p
Analog output	RGB (2): SDTV (NTSC/PAL) Y/C (2): SDTV (NTSC/PAL) Composite: SDTV (NTSC/PAL)
Color adjustment	Black, Red, Green, Blue, R-Hue, Chroma; 9 settings
Detail	Hi, LO; 9 settings
Contrast (gamma)	9 settings
BLD	Hi, Mid, Lo, Off
Picture in picture	On, Off; Size: 1/4, 1/3
Auto gain control	Off, +3 db, +6 db
Iris	Average / Peak
Zoom	Electric zoom: x1.0 – x2.0; 0.05 steps
Lamp rated value	Main lamp: 11.7 V 150 W Xenon lamp Emergency lamp: 12 V 75 W Halogen lamp
Brightness control	9 settings
Lamp cooling method	Forced air cooling
Air supply pump	Hi, Low, Off
Power	120 V 60 Hz 2.7 A / 230 V 50 Hz 1.4 A
Dimensions (W x D x H)	375 x 495 x 190 mm (including projections)
Weight	17.0 kg

## Ultrasonic Processor

### ▶ SU-8000



Power supply	AC120 V	AC230 V
	60 Hz	50 Hz
	2.2 A	1.4 A
Current consumption (rated)	1.8 A	1.2 A
Applicable scopes	EG-530U series scope	
	EB-530U series scope	
Video output terminal	Video terminal (1 channel)	
	S video terminal (1 channel)	
	RGB PC terminal (1 channel)	
	RGB PC/TV terminal (1 channel)	
	DVI image input terminal (1 channel)	
Audio output terminal	HD-SDI terminal (2 channels)	
	RCA terminal (1 channel)	
Video input terminal	DVI image input terminal (1 channel)	
	S video terminal (PROCESSOR) (1 channel)	
	S video terminal (SP702) (1 channel)	

Control terminal	Remote terminal (2 channels)	
	Foot Switch terminal (1 channel)	
	Keyboard terminal (1 channel)	
	RS232C terminal (PROCESSOR) (1 channel)	
	RS232C terminal (SP702) (1 channel)	
Network terminal (1 channel)	Ethernet (100 BaseTX)	
Image storage	Storage	CF memory card, networked shared folder (FTP, DICOM)
	File format	TIFF, JPEG
External dimensions (W x H x D)	375 x 215 x 445 mm (including protruding parts)	
Weight	14 kg	

---

**FUJIFILM**

**FUJIFILM Europe GmbH**

Heesenstr. 31, 40549 Düsseldorf, Germany  
Tel.: +49 211-50 89 0, Fax: +49 211-50 89 8700  
[www.fujifilm.eu](http://www.fujifilm.eu)